

PRESSURIZED OUTDOOR CAMERA HOUSINGS

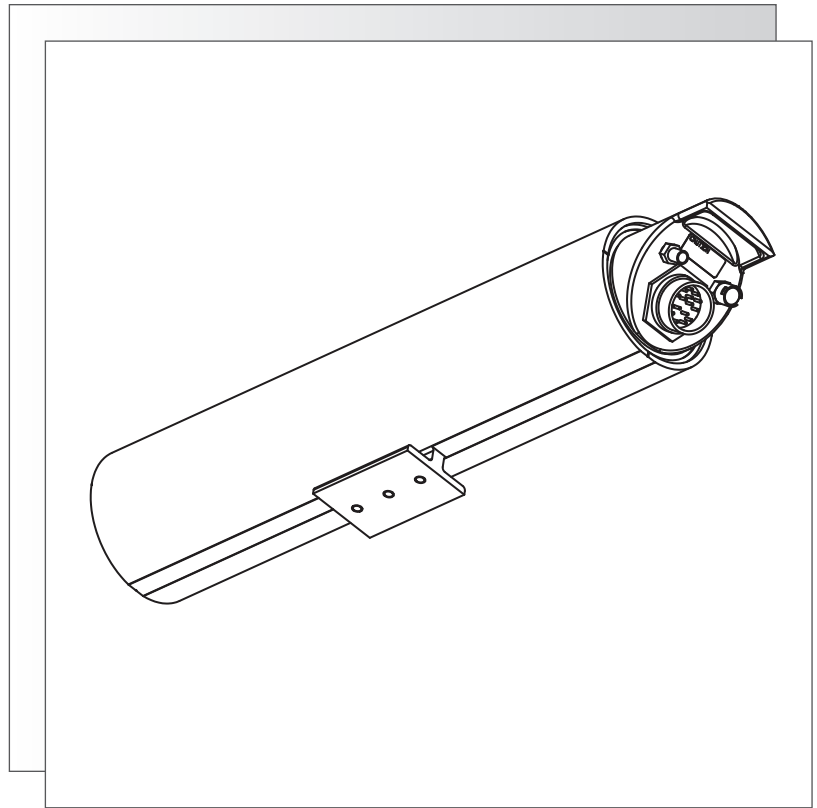

HS9384-xHP SERIES

IMPORTANT SAFEGUARDS

1. Read Instructions - All the safety and operating instructions should be read before the unit is operated.
2. Retain Instructions - The safety and operating instructions should be retained for future reference.
3. Heed Warnings - All warnings on the unit and in the operating instructions should be adhered to.
4. Follow Instructions - All operating and use instructions should be followed.
5. Cleaning - Unplug the unit from the outlet before cleaning. Do not use liquid cleaners or aerosol cleaners. Use a damp cloth for cleaning.
6. Attachments - Do not use attachments not recommended by the product manufacturer as they may cause hazards.
7. Accessories - Do not place this unit on an unstable stand, tripod, bracket, or mount. The unit may fall, causing serious injury to a person and serious damage to the unit. Use only with a stand, tripod, bracket, or mount recommended by the manufacturer, or sold with the product. Any mounting of the unit should follow the manufacturer's instructions, and should use a mounting accessory recommended by the manufacturer.

An appliance and cart combination should be moved with care. Quick stops, excessive force, and uneven surfaces may cause the appliance and cart combination to overturn.

8. Ventilation - Openings in the enclosure, if any, are provided for ventilation and to ensure reliable operation of the unit and to protect it from overheating. These openings must not be blocked or covered. This unit should not be placed in a built-in installation unless proper ventilation is provided or the manufacturer's instructions have been adhered to.
9. Power Sources - This unit should be operated only from the type of power source indicated on the marking label. If you are not sure of the type of power supply you plan to use, consult your appliance dealer or local power company. For units intended to operate from battery power, or other sources, refer to the operating instructions.
10. Grounding or Polarization - This unit may be equipped with a polarized alternating-current line plug (a plug having one blade wider than the other). This plug will fit into the power outlet only one way. This is a safety feature. If you are unable to insert the plug fully into the outlet, try reversing the plug. If the plug should still fail to fit, contact your electrician to replace your obsolete outlet. Do not defeat the safety purpose of the polarized plug.

Alternately, this unit may be equipped with a 3-wire grounding-type plug, a plug having a third (grounding) pin. This plug will only fit into a grounding-type power outlet. This is a safety feature. If you are unable to insert the plug into the outlet, contact your electrician to replace your obsolete outlet. Do not defeat the safety purpose of the grounding-type plug.
11. Power-Cord Protection - Power-supply cords should be routed so that they are not likely to be walked on or pinched by items placed upon or against them, paying particular attention to cords and plugs, convenience receptacles, and the point where they exit from the appliance.
12. Power Lines - An outdoor system should not be located in the vicinity of overhead power lines or other electric light or power circuits, or where it can fall into such power lines or circuits. When installing an outdoor system, extreme care should be taken to keep from touching such power lines or circuits as contact with them might be fatal. U.S.A. models only - refer to the National Electrical Code Article 820 regarding installation of CATV systems.
13. Overloading - Do not overload outlets and extension cords as this can result in a risk of fire or electric shock.
14. Object and Liquid Entry - Never push objects of any kind into this unit through openings as they may touch dangerous voltage points or short-out parts that could result in a fire or electric shock. Never spill liquid of any kind on the unit.
15. Servicing - Do not attempt to service this unit yourself as opening or removing covers may expose you to dangerous voltage or other hazards. Refer all servicing to qualified service personnel.
16. Damage Requiring Service - Unplug the unit from the outlet and refer servicing to qualified service personnel under the following conditions:
 - a. When the power-supply cord or plug is damaged.
 - b. If liquid has been spilled, or objects have fallen into the unit.
 - c. If the unit has been exposed to rain or water.
 - d. If the unit does not operate normally by following the operating instructions. Adjust only those controls that are covered by the operating

instructions, as an improper adjustment of other controls may result in damage and will often require extensive work by a qualified technician to restore the unit to its normal operation.

- e. If the unit has been dropped or the cabinet has been damaged.
 - f. When the unit exhibits a distinct change in performance--this indicates a need for service.
17. Replacement Parts - When replacement parts are required, be sure the service technician has used replacement parts specified by the manufacturer or have the same characteristics as the original part. Unauthorized substitutions may result in fire, electric shock or other hazards.
 18. Safety Check - Upon completion of any service or repairs to this unit, ask the service technician to perform safety checks to determine that the unit is in proper operating condition.
 19. Coax Grounding - If an outside cable system is connected to the unit, be sure the cable system is grounded. U.S.A. models only--Section 810 of the National Electrical Code, ANSI/NFPA No.70-1981, provides information with respect to proper grounding of the mount and supporting structure, grounding of the coax to a discharge unit, size of grounding conductors, location of discharge unit, connection to grounding electrodes, and requirements for the grounding electrode.
 20. Lightning - For added protection of this unit during a lightning storm, or when it is left unattended and unused for long periods of time, unplug it from the wall outlet and disconnect the cable system. This will prevent damage to the unit due to lightning and power-line surges.

FCC & ICES INFORMATION (U.S.A. and Canadian Models Only)

WARNING - This equipment has been tested and found to comply with the limits for a Class B digital device, pursuant to Part 15 of the FCC Rules and ICES-003 of Industry Canada. These limits are designed to provide reasonable protection against harmful interference when the equipment is operated in a residential installation. This equipment generates, uses and can radiate radio frequency energy and, if not installed and used in accordance with the instructions, may cause harmful interference to radio communications. However, there is no guarantee that interference will not occur in a particular installation. If this equipment does cause harmful interference to radio or television reception, which can be determined by turning the equipment off and on, the user is encouraged to try to correct the interference by one or more of the following measures:

- Reorient or relocate the receiving antenna.
- Increase the separation between the equipment and receiver.
- Connect the equipment into an outlet on a circuit different from that to which the receiver is connected.
- Consult the dealer or an experienced radio/TV technician for help.

Intentional or unintentional changes or modifications not expressly approved by the party responsible for compliance shall not be made. Any such changes or modifications could void the user's authority to operate the equipment.

The user may find the following booklet prepared by the Federal Communications Commission helpful: "How to Identify and Resolve Radio-TV Interference Problems". This booklet is available from the U.S. Government Printing Office, Washington, DC 20402, Stock No. 004-000-00345-4.

SAFETY PRECAUTIONS:

This label may appear on the bottom of the unit due to space limitations.

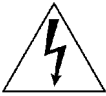

CAUTION
RISK OF ELECTRIC SHOCK. DO NOT OPEN!



CAUTION: TO REDUCE THE RISK OF ELECTRICAL SHOCK, DO NOT OPEN COVERS. NO USER SERVICEABLE PARTS INSIDE. REFER SERVICING TO QUALIFIED SERVICE PERSONNEL.



The lightning flash with an arrowhead symbol within an equilateral triangle is intended to alert the user to the presence of uninsulated "dangerous voltage" within the product's enclosure that may be of sufficient magnitude to constitute a risk of electric shock to persons.



The exclamation point within an equilateral triangle is intended to alert the user to presence of important operating and maintenance (servicing) instructions in the literature accompanying the appliance.

WARNING

TO PREVENT FIRE OR SHOCK HAZARD, DO NOT EXPOSE UNPROTECTED COMPONENTS TO RAIN OR MOISTURE.



WARNING: Electrostatic-sensitive device. Use proper CMOS/MOSFET handling precautions to avoid electrostatic discharge.

NOTE: Grounded wrist straps must be worn and proper ESD safety precautions observed when handling the electrostatic-sensitive printed circuit boards.

CAUTION



Pressurized container. DO NOT exceed 10 PSI (0.69 bar) at one atmosphere. Refer servicing to qualified service personnel.

DESCRIPTION

The HS9384-xHP Series of pressurized housings are attractive aluminum enclosures designed for outdoor CCTV camera installations.

Attention

These instructions give installation and operating procedures for pressurized camera housings. These environmental resistant camera housings provide ideal environments for demanding CCTV applications.

Power

These housings employ an integral heater which will add an additional 10 watts to the power consumption.

ENVIRONMENTAL ENCLOSURE

Construction

This housing is a self contained unit with a single corrosion-resistant connector for power, video and lens control. A mating connector is provided for each housings. The exterior of the camera housing is 4 mm (0.16 inch) aluminum, which insures a very rigid and rugged structure. The camera housing is sealed at both ends by radial pressure "O" rings to create a tight seal; front-to-back motion is prevented by a retaining ring in the front and back. Chemically strengthened glass is used for the faceplate for maximum strength and safety.

The housing is fitted with a standard Schrader valve to allow pressurization with dry nitrogen or dry filtered compressed air to 10PSI (0.69 bar) nominal at one atmosphere. An over pressurization safety relief valve is mounted on the rear cap along with the Schrader valve. The purpose of the relief valve is to provide a safety pressure blow-off should internal pressure exceed 20PSI (1.38 bar) at one atmosphere. A pressurization warning label is visible on the back of housing.

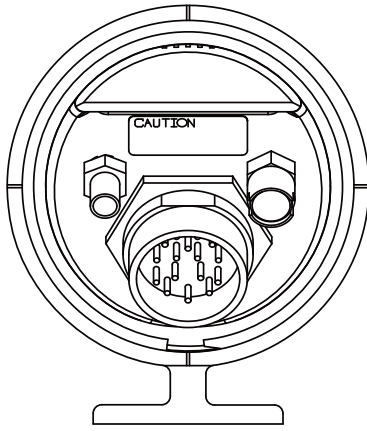

Pressure Warning Label

Heater

The front end-cap contains a glass viewing window. The integral heater/defogger is mounted to the camera cradle and will transfer heat to the window to minimize fogging of the window in high humidity areas and/or freezing under cold temperature conditions.

WARNING



Do Not Exceed 30 VAC Input on 24 VAC models. Operation above 30 VAC violates low voltage operation (class 2 specifications). Normal operation is 24 VAC.

I UNPACKING

Unpack carefully. This is electronic equipment and should be handled with care.

Check for the following items:

- Verify the unit model number.
- Verify that parts listed as follows have been included. See **INSTALLATION**.

Hardware Kit 315 1514 005

Quantity	Part Description
3	Cable Tie
2	BHCS, 1/4-20 x 1/4-inch
1	BHCS, 1/4-20 x 5/8-inch
1	BHCS, 1/4-20 x 3/4-inch
3	BHCS, 1/4-20 x 1/2-inch
1	BHCS, 1/4-20 x 3/8-inch
1	BHCS, 1/4-20 x 1 1/4-inch
1	0.4 mm (0.016-inch) Plastic Spacer
1	1.65 mm (0.065-inch) Plastic Spacer 1/4-20
1	3.9 mm (0.154-inch) Plastic Spacer
1	7.4 mm (0.292-inch) Plastic Spacer
1	9.8 mm (0.385-inch) Plastic Spacer
1	3/8-inch NPT Plug
2	Pull Seals

Note: "BHCS" = Button Head Cap Screw

If an item appears to have been damaged in shipment, replace it properly in its carton and notify the shipper. If any items are missing, notify an Aigis Mechnronics Sales Representative or Customer Service. The shipping carton is the safest container in which the unit may be transported. Save it for possible future use.

2 SERVICE

If the unit ever needs repair service, the customer should contact Aigis Mechnronics for return authorization and shipping instructions.

3 CARE AND MAINTENANCE

Clean the viewing window as needed with a mild, nonabrasive detergent in water and a soft cloth.

4 INSTALLATION

Attention: Installation should be performed by qualified service personnel only in accordance with the National Electrical Code or applicable local codes.

Cable Routing

Caution: Be sure cable wires do not pinch or rub when connected to pan/tilt units. Frayed, pinched, or broken wires can cause fire, shock hazards or system failure.

4.1 Model Designation

Model No.	Rated Input	Voltage Range	Voltage Output	Nominal Power ²
HS9384-2HP	24 VAC, 50/60 Hz	21.6 to 26.4	—	30 W
HS9384-5HP ¹	230 VAC, 50/60 Hz	207 to 253	24 VAC, 50/60 Hz	30 W
HS9384-6HP ¹	115 VAC, 50/60 Hz	108 to 132	24 VAC, 50/60 Hz	30 W

1. The power transformers included with these housings are used to provide heater power and can be used to provide isolated camera power.
2. Heater requires 10 watts.

Do Not Exceed 30 VAC Input on 24 VAC models.

Operation above 30 VAC violates low voltage operation (Class 2 Specifications). Normal operation is 24 VAC.

Maximum Camera/Lens Size: HS9384-5HP & 6HP:

Accepts cameras up to 64 W x 54 H mm (2.5 x 2.1 in), lenses up to 67 W x 75 H mm (2.6 x 2.9 in), and camera/lens combinations up to 292 mm (11.5 in).

HS9384-2HP:

Accepts cameras up to 64 W x 54 H mm (2.5 x 2.1 in), lenses up to 67 W x 75 H mm (2.6 x 2.9 in), and camera/lens combinations up to 355 mm (14.0 in).

4.2 Tools Required

- Flat head screwdriver
- 5/32-inch (or 4 mm) hex wrench
- 5/16-inch (or 8 mm) hex wrench
- Wire cutter/stripper/crimper tool

4.3 Cradle Removal

1. Ensure that the housing is depressurized before attempting to remove the cradle. Unscrew the cap from the Schrader valve and depress the plunger until gas no longer flows from the valve.
2. Remove the cradle from the housing by first removing the snap ring at the rear of the housing. (see **Figure 1**). Insert a flat-blade screwdriver under the notch in the snap ring, then pry outward to remove the snap ring.

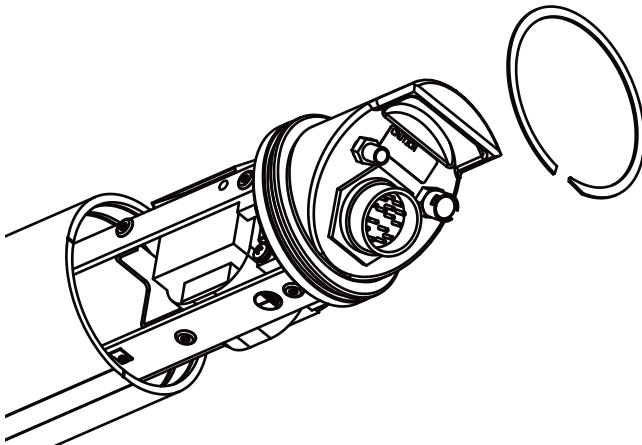

Figure 1 Removing Cradle Assembly

3. Remove the cradle assembly by simultaneously grasping the rear handle and the housing shell, then pull the cradle assembly out of the housing. Be sure to keep the edges of the end caps clean and free of scratches.

4.4 Camera/Lens Installation

With the cradle removed from the housing, follow all of the steps below.

1. Place the camera/lens combination into the cradle assembly.

Fixed Lens Cameras: Position the camera/lens 1mm (0.04-inch) away from the faceplate. Secure the camera/lens to the cradle with a 1/4-20 button head cap screw (BHCS) and the appropriate plastic spacer from the hardware kit (see **Figure 2**).

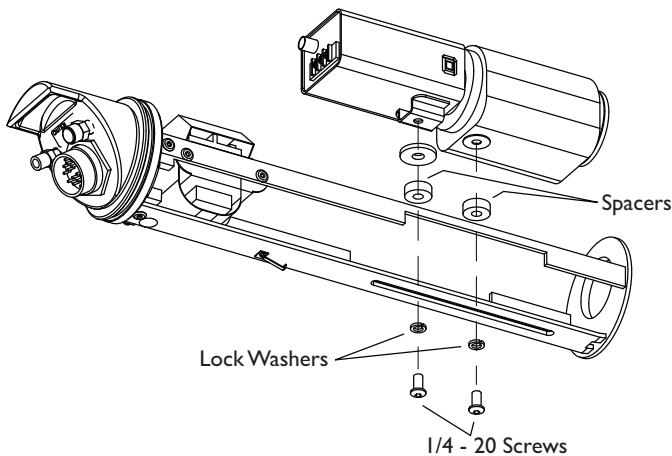

Figure 2 Mounting Camera and Lens

Zoom Lens Cameras: Allow 3/16-inch (5 mm) clearance from the front face of the lens to the front faceplate of the cradle during the camera/lens assembly. This clearance provides the necessary space for the lens to extend outward when zooming. Secure both the camera and the lens to the cradle with the 1/4-20 BHCS and appropriate plastic spacer.

2. The HS9384 Series housings allow the use of 24 VAC cameras, regardless of the supply voltage to the housing. The model numbers ending in -2HP accept 24 VAC input that is used to power the internal heater and the camera. Model numbers ending in -6HP utilize a transformer that accepts 120 VAC and outputs 24 VAC to the heater, and either 24 VAC or 12 VAC to the camera depending on the output wires used. 120VAC can also be provided to the camera by connecting it to the input wires before they connect to the transformer.

4.4.1 HS9384-6HP Housings

The HS9384-6HP housings can easily be used with either 115 volt or 24 volt cameras.

The internal transformer provides 24 VAC for both the heater/defogger and 24 volt camera power.

For 115 volt cameras:

1. Installing a 115 volt camera into the HS9384-6HP housing requires inserting both the field supply wires (115 VAC) and a section of hook-up wire (not included, minimum 20 AWG wire) into the unused side of the Wago connectors (provided), then connecting the other end of the hook-up wire to the camera's 110 VAC input. Repeat for pins 1 and 6 (see **Figure 3**).
2. The secondary flying leads (white/black striped) will not be used in this application and should be taped to prevent shorting. See wiring diagram **Figure 3** for clarification.

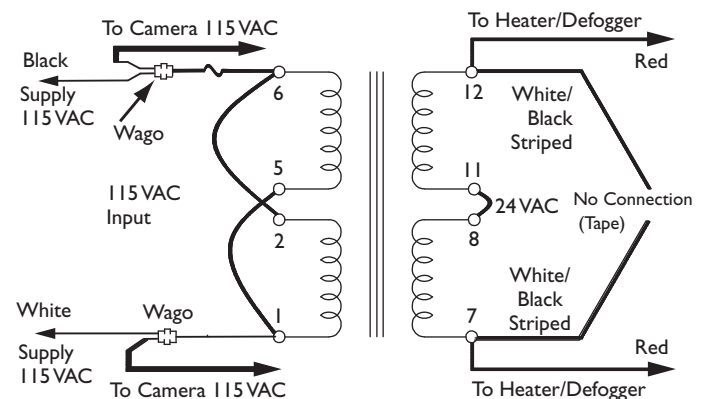

Figure 3 HS9384-6HP Transformer Wired for 115 Volt Camera

For 24 volt cameras:

1. Installing a 24 volt camera into the HS9384-6HP housing utilizes the internal transformer for camera power.
2. Connect the supply (115 VAC) to the primary flying leads of the transformer (white wire/pin 1, black wire/pin 6). Use the wago connectors provided for this connection.
3. Connect the secondary flying leads (white/black striped wires/pins 7 and 12) to the camera's 24 volt input. See wiring diagram **Figure 4** for clarification.

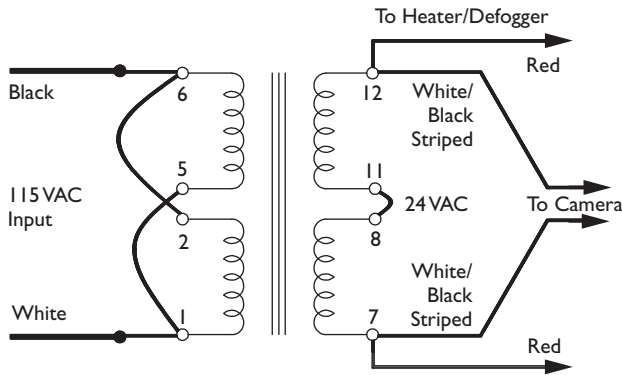

Figure 4 HS9384-6HP Transformer Wired for 24 Volt Camera

For 230 volt cameras:

1. Installing a 230 volt camera into the HS9384-5HP housing requires inserting both the field supply wire (115 VAC) and a section of hook-up wire (not included, minimum 20 AWG wire) into the unused side of the Wago connectors (provided), then connecting the other end of the hook-up wire to the camera's 230 VAC input. Repeat for pins 1 and 6. (see **Figure 5**).
2. The secondary flying leads (white/black striped) will not be used in this application and should be taped to prevent shorting. See wiring diagram **Figure 5** for clarification.

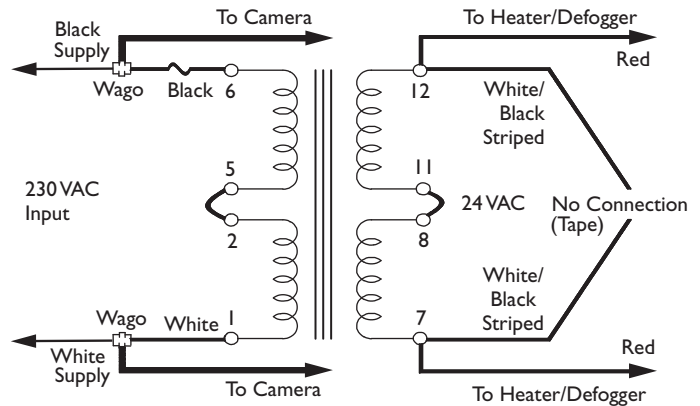

Figure 5 HS9384-5HP Transformer Wired for 230 Volt Camera

4.4.2 HS9384-2HP Housings

These housings are to be connected to 24 VAC only and are designed to be used where site power is 24 volts.

The HS9384-2HP housings are designed to be used with 24 volt cameras only.

1. Connect the supply (24 VAC) to the unoccupied sides of the gray Wago connectors.
2. Connect the flying leads (white and black) to the camera's 24 volt input.

4.4.3 HS9384-5HP Housings

These housings require connection to 230 VAC and are designed to be used where site power is 230 volts.

The HS9384-5HP housings can easily be used with either 230 volt or 24 volt cameras.

The internal transformer provides 24 VAC for both the heater and 24 volt camera power.

For 24 volt cameras:

1. Installing a 24 volt camera into the HS9384-5HP housing utilizes the internal transformer for camera power (see **Figure 6**).
2. Connect the supply (230 VAC) to the Wago connectors (provided).
3. Connect the secondary flying leads (white/black) to the camera's 24 volt input. Refer to the wiring diagram for clarification.

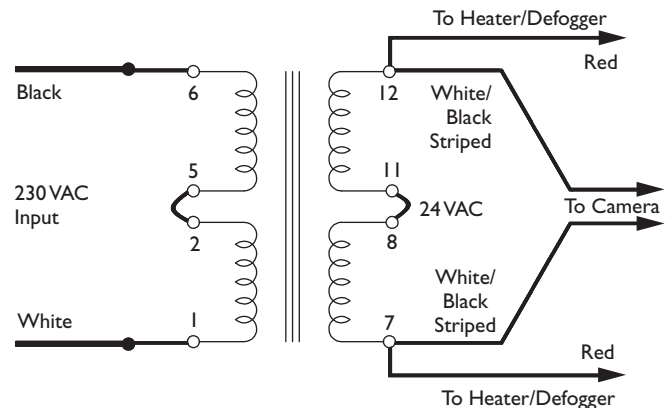

Figure 6 HS9384-5HP Transformer Wired for 24 Volt Camera



Do not remove the transformer insulator. No user serviceable parts are underneath.

5. WIRING DIAGRAM

16-Pin Models

All electrical connections are made via the single corrosion-resistant connector on the rear panel. A mating connector and crimp pins are supplied. The pins will accept wire from a minimum of 0.5 mm² (20 AWG) to a maximum of 1.5 mm² (16 AWG). Crimp the wire to the connector using an appropriate crimp tool. Information on sync and video hookups is given in the basic camera instructions. Zoom lens models require a zoom lens control system.

Wiring Diagram

A	←————→	NC
B	←————→	NC
C	←————→	NC
D	←————→	Focus - Black
E	←————→	NC
F	←————→	Sync/Video Shield - Coax
G	←————→	Video Output - Coax
H	←————→	NC
J	←————→	Ground - Green
K	←————→	AC Neutral - White
L	←————→	Ac Hot - Black
M	←————→	NC
N	←————→	NC
P	←————→	Zoom - Green
R	←————→	Lens Common - White/Gray
S	←————→	NC

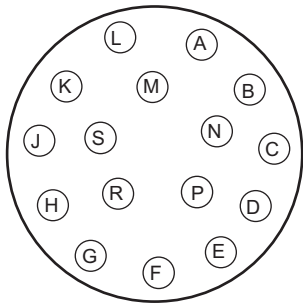

16 -Pin Connector
Pin Designation

Tools For Use With Connectors

The following tools are available from:

Daniels Manufacturing Corporation
6103 Anno Avenue
Orlando, FL 32809
407-855-6161

Crimp Tool: AF8 (M22520/1-01).
Crimp Tool Turret: TH1A (M22520/1-02).
Insertion Tool: DAK16B (M81969/17-04)
Removal Tool: DAK16A (M81969/19-08)

The following tools are available from:

Amphenol Corp.
40-60 Delaware Ave.
Sidney, NY 13838-1395
607-563-5011

Insertion Tool: 11-7401-16 (M81969/17-04)
Removal Tool: 11-7880-16 (M81969/19-08)

6. Re-assembly Instructions

1. Install a Desiccant Kit inside the housing before reinstalling the cradle into the housing shell.
2. Pressurize the housing to 10 PSI (0.69 bar) with filtered and dry compressed air or dry nitrogen gas. If the internal pressure exceeds 20 PSI (1.38 bar), the over-pressurization relief valve will begin to release pressure. The valve will reseal at or about 11 PSI (0.76 bar).

Notes:

- 1) Caution: Failure to provide a dry internal environment within the housing could lead to moisture condensation within the housing under certain conditions, adversely affecting camera and lens performance
- 2) A desiccant kit is available to help ensure a dry internal environment within the housing. Whenever the housing is opened for service, a new kit should be installed. The desiccant pack can be placed on an accessible portion of the camera cradle using the double sided tape provided.
- 3) Purge Moisture: to purge trapped moisture from inside the housing, do the following:
 - a. Pressurize the housing to 10 PSI (0.69 bar) with a source of dry nitrogen (preferred) or filtered and dry compressed air.
 - b. Allow the unit to sit for at least two minutes, and then release the pressure.
 - c. Repeat steps a. and b. Each time this cycle is completed, approximately 40% of the trapped moisture is removed from the housing. Complete the cycle 4 times and approximately 87% of the moisture will be removed. Completing the cycle 5 times and over 92% of the moisture will be removed.



mechtronics

©2010 Aigis Mechtronics

1124 Louise Road, Winston-Salem, NC 27107-5450

Tel: 336.785.7740 Fax: 336.785.7744

I00 0025 002 AIG 1/10

Data subject to change without notice

Printed in U.S.A.